

Fume Extractor

FE-110 & FE-220

Portable Fume Extractor

The Pro Spot line of Fume Extractors is designed to remove harmful welding fumes in a variety of applications. Fumes are captured using a 6' Flame Retardant Flexible Hose. The Pro Spot Fume Extractors are extremely portable, quiet, efficient and are available in either 110 or 220VAC.



Lowest Reach

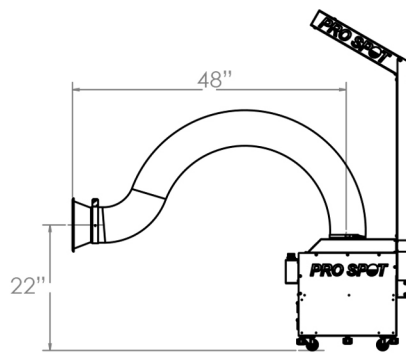

Highest Reach

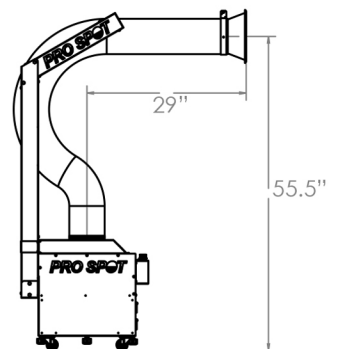

220° Radius

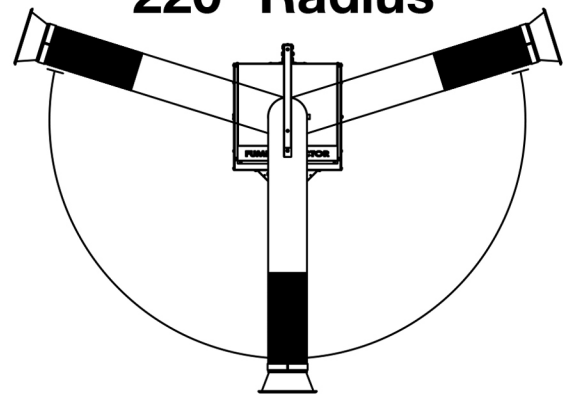

Technical Specifications

FE-110

FE-220 (Europe)

Input Voltage:

110VAC

220VAC

CFM:

100 -1600

Filters:

Carbon Pre Filter
99.99% Efficiency @ 0.3 Micron

HEPA Filter
99.99% Efficiency @ 0.3 Micron

Cabinet Size:

17.5"W x 20"H x 20"L

Flexible Hose Size:

6" Diameter x 72" Length

Working Sound Level:

65dba

Weight:

55lb (24.9kg)

PRO SPOT
A U S T R A L I A



Easy to Replace Air Filters

Key Features:

- Low Maintenance
- Quick Change Filters
- Extremely Portable
- Variable Speed Fan Control
- Steel Construction
- Promotes Safer Work Environment



Built-in Fume Extractor Available on the Mobile Weld Station

The Mobile Weld Station (MWS) is extremely portable, efficient and is available in either 110 or 220VAC. It has the option to add a Built-In Fume Extractor. The all-in-one dent station can be set up for Aluminum, Steel or Plastic Repair with a Fume Extractor that is designed to remove harmful welding fumes from any application.

Simple Upgrade:

Add the NEW Built-in Fume Extractor to your existing unit by simply swapping out the tool boards.

Technical Specifications	FE-110	FE-220 (Europe)
Input Voltage:	110VAC	220VAC
CFM:	100 -1600	
Filters:	Carbon Pre Filter 99.99% Efficiency @ 0.3 Micron	
	HEPA Filter 99.99% Efficiency @ 0.3 Micron	
Cabinet Size:	26.5"W x 32"H x 18"L	
Flexible Hose Size:	4" Diameter x 100" Length	
Working Sound Level:	65dba	
Weight:	55lb (24.9kg)	

Imported and Distributed by **Prospot Australia**

22 Montefiore Street
Fairfield VIC 3078

Toll Free : 1800 287 776

E-mail : sales@prospot.com.au

Web : www.prospot.com.au