

Provides flexible yet structural repair by welding the metal staple in to the plastic surface

- Bumper Repair
- Headlight Assembly Repair
- Welds Broken Plastic Tabs
- Other General Plastic Repair



Easy to Use

Plug the HSW-200 into any outlet between 110v - 240v, the voltage is detected and adapted to automatically . Once the staple welder is plugged in, switch it on and your ready to repair a variety of plastic parts.

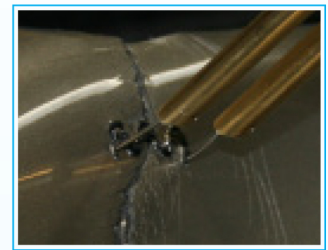
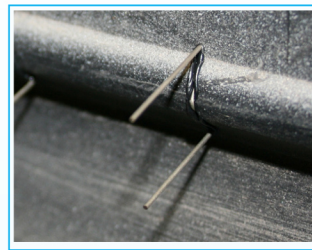

HIGHLY VERSATILE:

The HSW-200 is designed for flexibility. For easy access to hard to reach areas there are 3 positions available. A must have feature.

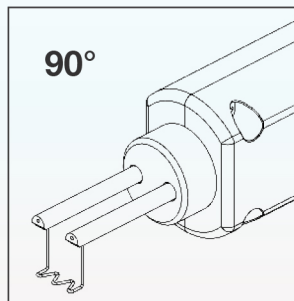
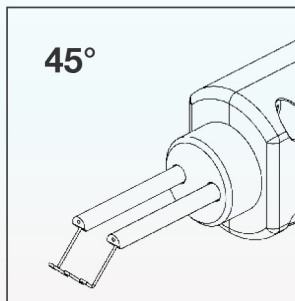
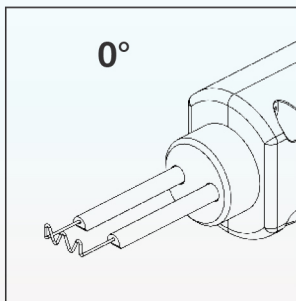

Can be plugged directly into your car power supply or a standard 12V AC Adaptor.



DIFFERENT STAPLES FOR DIFFERENT APPLICATIONS

Part#
90-0392

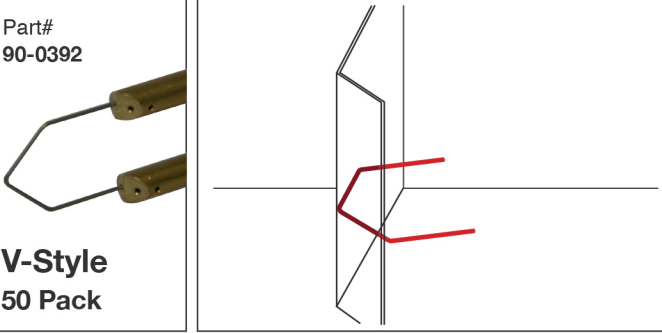

V-Style
50 Pack

The **V-Style** staples are designed to weld inside corners (such as the inside of two overlapping plastic pieces that join at an angle).

Part#
90-0390

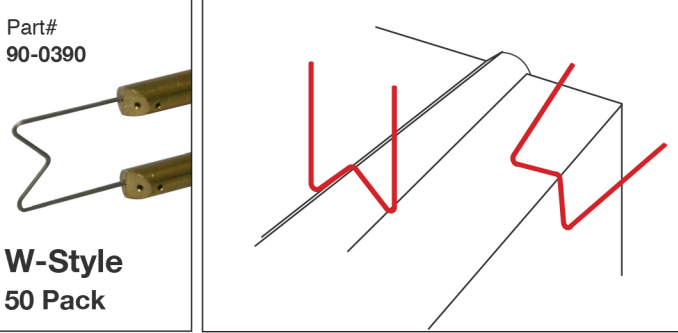

W-Style
50 Pack

The **W-Style** staples are made for outside corners and ridges.

Part#
90-0393

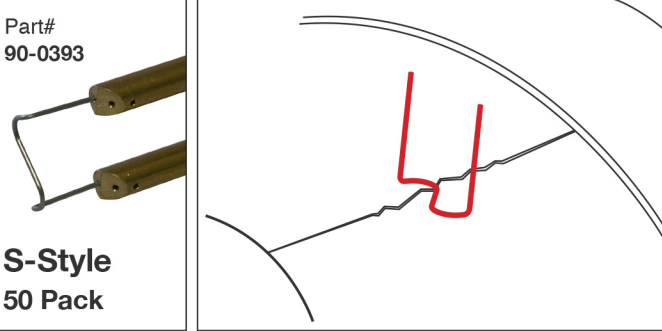

S-Style
50 Pack

The **S-Style** staples are designed to stitch broken seams and cracked plastic. Thanks to its flexible nature the S-Style staple works great on curved surfaces.

Part#
90-0391

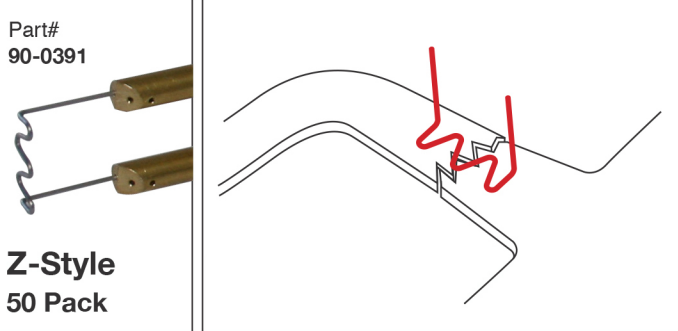

Z-Style
50 Pack

The **Z-Style** staples are great for exceptionally strong plastic repair, made for stitching broken seams and cracks.



The HSW-200 Comes Standard With:

- Plastic carrying case
- HSW-200 plastic staple gun attached to the 12v power supply with a 3' cable.
- 10' long power cord
- A 50 pack of the V-style, W-style, S-style, and Z-style staples.

Technical Specifications:

Shipping Weight: 5 lbs. (2.27 k)

Case Dimensions: 14" x 10" x 3.5"
(35.56cm x 25.4cm
x 8.89cm)

Auto Input Voltage: 110V / 220V

Staple Types:

V-Style S-Style
(interior angles) (curved surfaces)

W-Style Z-Style
(exterior angles) (flat surfaces)

Imported and Distributed by **Prospot Australia**
22 Montefiore Street
Fairfield VIC 3078

Toll Free : 1800 287 776
E-mail : sales@prospot.com.au
Web : www.prospot.com.au