



COMPONENT LIST

CL-i5s Rev 1.0

**The Pro Spot i5s comes with below listed parts except for parts listed as "Optional"

PRO SPOT

ORDER ONLINE @ store.prospot.com

Double Side Gun

- 90-2362 Shaft Protector Ring, i5s
- 90-2480 Electrode Shank, Tapered End Q-Connect, 4ct
- 90-2377 Shank Protector Ring, i5s
- 52-0093 O-Ring, #112, BUNA-N

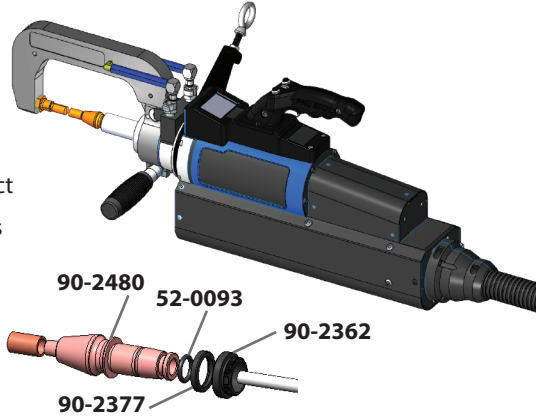

220V

400V

i5s Serial #

Checked by:

Overhead Boom

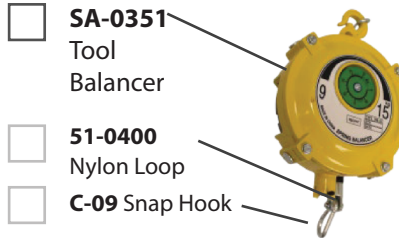
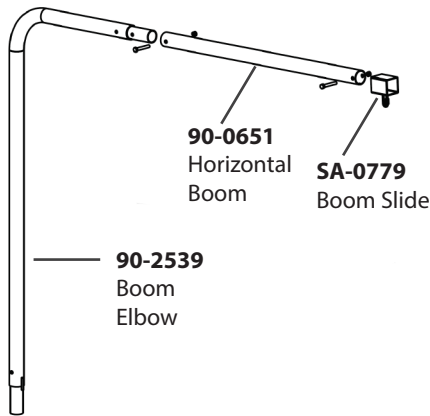

PS-004 Cap Removal Tool



SHIPPING DATA:
 Dimensions: 38"x47"x54.5"
 Weight: 440lbs

i5s ACCESSORY KIT

SA-0760 Rev.A



CLT-58A Allen Wrench - 5mm



1 pc.

52-0086 O-Ring - Arm Side



5 pc.

52-0093 O-Ring - Gun Side



5 pc.

90-2362 Shaft Protector Ring, i5s



2ea

S-617 Screw, FHMS, M6 X 12MM, Brass 1ea



1 pc.

90-1385 Wheelhouse Electrode Washer Ø1.394"



1ea

PS-032 Weld Cap, 4RW, .375" Radius, Female



6ea

90-2377 Shank Protector Ring, i5s



2ea

PS-038 Weld Cap, 3/8" Full Domed 4RW Female, Honda Approved



2ea

PS-036 Weld Cap, 4RW, .375" Radius, Male

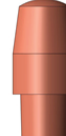

2ea



COMPONENT LIST

CL-i5s Rev 1.0

**The Pro Spot i5s comes with below listed parts except for parts listed as "Optional"

PRO SPOT

ORDER ONLINE @ store.prospot.com

50-2010 Weld Coupon, 2"x10"
18 Gauge Steel



2ea

80-0001 Protective Cover



1ea

SA-0515 Cable Hanger

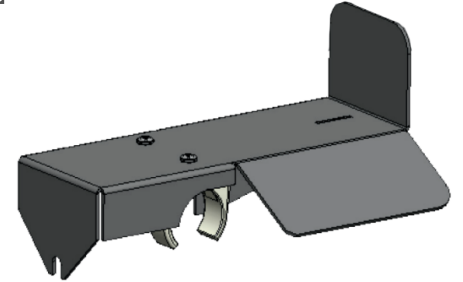

1ea

PSW-080 C-ARM, 80mm Depth
1ea

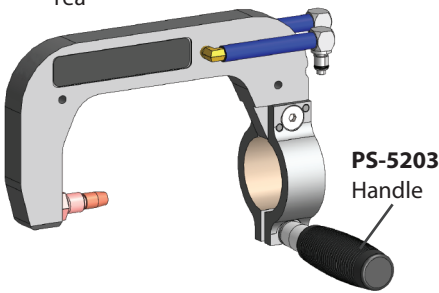

1. **90-1711** Divider
2. **52-0086** O-ring
3. **90-1710** Screw-In Shank
4. **PS-0032** Weld Cap

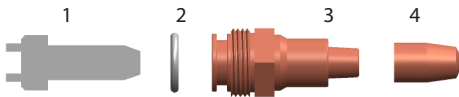

PSW-WH-090
Wheelhouse Arm, 90mm Depth
1ea

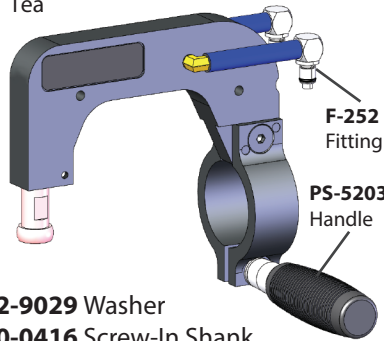

1. **52-9029** Washer
2. **90-0416** Screw-In Shank
3. **PS-1135** Weld Washer
4. **S-617** Cap Screw



PSW-520
Extension Arm,
520mm Depth
1ea

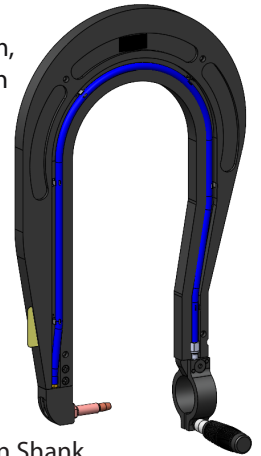

1. **90-1726** Divider
2. **52-0086** O-ring
3. **90-1717** Screw-In Shank
4. **PS-0032** Weld Cap

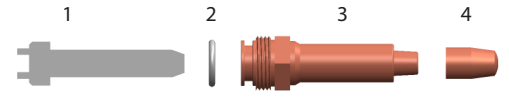

OPTIONAL

CX-i5s C-X Arm

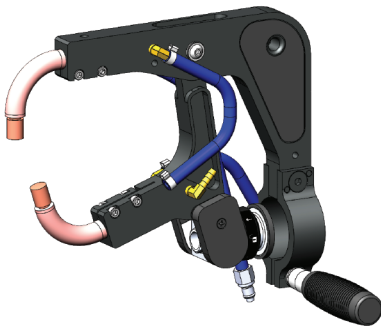

PSW-406 406mm Extension Arm

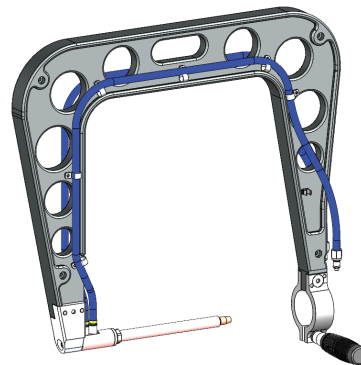

PSW-600 600mm Extension Arm

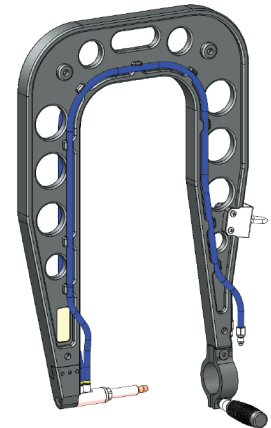

85-0018 (Shunting Plier)



DRESSER (See table on page 3
for part numbers)



Blade(See table on page 3
for part numbers)





COMPONENT LIST

CL-i5s Rev 1.0

**The Pro Spot i5s comes with below listed parts except for parts listed as "Optional"



ORDER ONLINE @ store.prospot.com

OPTIONAL

4RW Weld Caps (Standard)

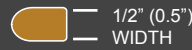

Cap Image			Coming soon		Coming soon					
Cap No.	PS-024 Male	PS-025 Female	Male	PS-038 Female		PS-022 Female	PS-035 Male	PS-023 Female	PS-036 Male	PS-032 Female
Shape	A-Cap		Honda Cap		B-Cap		F-Cap		.375 Radius	
Dresser	PLT-50/A		PLT-44/A		PLT-48/A		PLT-49/A		PLT-46/A	
Blade	PLT-29		50-9038		50-9032		50-9031		50-9025	
Chuck	PLT-02		PLT-02		PLT-02		PLT-02		PLT-02	
Ring	PLT-03		PLT-03		PLT-03		PLT-03		PLT-03	
Nut	PLT-01		PLT-01		PLT-01		PLT-01		PLT-01	
Tip Dresser	PLT-29ED		82-0038		82-0032		82-0031		82-0025	

5RW Weld Caps (For Future Use)



Cap Image					Coming soon				Coming soon	
Cap No.	PS-031 Male	PS-030 Female	PS-041 Male	PS-040 Female		PS-027 Female		PS-029 Female		PS-033 Female
Shape	A-Cap		Honda		B-Cap		F-Cap		.375 Radius	
Dresser	PLT-52/A		PLT-43/A		PLT-51/A		PLT-45/A		PLT-47/A	
Blade	50-9030		50-9040		50-9027		50-9033		50-9026	
Chuck	PLT-02		PLT-02		PLT-02		PLT-02		PLT-02	
Ring	PLT-04		PLT-04		PLT-04		PLT-04		PLT-04	
Nut	PLT-01		PLT-01		PLT-01		PLT-01		PLT-01	
Tip Dresser	82-0030		82-0040		82-0027		82-0033		82-0026	



Dresser comes with pneumatic drill and sharpener



Tip Dresser comes with blade as ordered (see above chart for proper dresser)

NOTE:

4RW and 5RW tip dresser housings are the same, with only the blade and "ring" being the difference between the versions. To change a 4RW to a 5RW, or vice versa, the proper ring has to be installed. PLT-03 is for 4RW caps and PLT-04 is for 5RW caps.